

ZIPPER and VELCRO CABLE COVERS

Cable covers are available in two types of material, soft woven nylon and flexible glove-soft leather.

Both types of material offer protection for expensive torch cables and hoses.

Careful workmanship and double stitching of the closure ensure long life. Cover ends are fused to resist fraying and cable ties are provided to secure the cover to the handle.

Cable covers are available with non-conductive zipper or with velcro closure.

The non-conductive zipper will not conduct "HF" current and is protected from hot metal contact by the overlap flap construction.

The velcro closure is not affected by burn or melt spots.

The full length closure allows installation without removing the torch from the machine.

3" wide zipper covers cover bundles up to 3/4" diameter, 4" wide up to 1.1/4" diameter.



WC-

Woven Cover - Black

Traditional woven nylon.
Soft and lightweight.
Good abrasion and tear resistance.



SC-

Safety Cover - Orange

Bright visible colour.
Soft and lightweight.
Good tear and abrasion resistance.

WC-3-10	3" Black Woven Cover 11ft - Zipper Closure	Each	24.00
WC-3-22	3" Black Woven Cover 24ft - Zipper Closure	Each	48.00
WC-3-10V	3" Black Woven Cover 11ft - Velcro Closure	Each	24.00
WC-3-22V	3" Black Woven Cover 24ft - Velcro Closure	Each	48.00
WC-4-10	4" Black Woven Cover 11ft - Zipper Closure	Each	31.50
WC-4-22	4" Black Woven Cover 24ft - Zipper Closure	Each	63.00
WC-4-10V	4" Black Woven Cover 11ft - Velcro Closure	Each	31.50
WC-4-22V	4" Black Woven Cover 24ft - Velcro Closure	Each	63.00
SC-3-10	3" Safety Orange Woven Cover 11ft - Zipper Closure	Each	34.60
SC-3-22	3" Safety Orange Woven Cover 24ft - Zipper Closure	Each	66.10
SC-3-10V	3" Safety Orange Woven Cover 11ft - Velcro Closure	Each	34.60
SC-3-22V	3" Safety Orange Woven Cover 24ft - Velcro Closure	Each	66.10



LC-

Leather Cover

Soft flexible leather.
Burn, spatter, tear
and abrasion resistant.

LC-3-10	3" Flexible Leather Cover 11ft - Zipper Closure	Each	39.00
LC-3-22	3" Flexible Leather Cover 24ft - Zipper Closure	Each	76.00
LC-3-10V	3" Flexible Leather Cover 11ft - Velcro Closure	Each	39.00
LC-3-22V	3" Flexible Leather Cover 24ft - Velcro Closure	Each	76.00

ZIPPER and VELCRO CABLE COVERS

INSTALLATION of ZIPPER COVERS

Lay cover flat, zipper side up, under extended torch leads with the zipper pull tab end of the cover at the torch handle. Insert cable tie with flat side towards the zipper.

Using the cable tie, attach the cable cover to the torch handle just above the end of the handle.

Tighten the cable tie to secure and trim any excess cable tie.

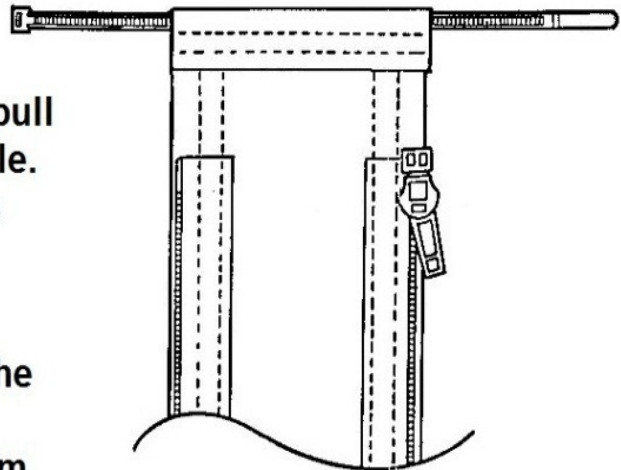

Engage the zipper at the torch end of the cable cover and begin closing the zipper, moving towards the machine end of the torch cable assembly.

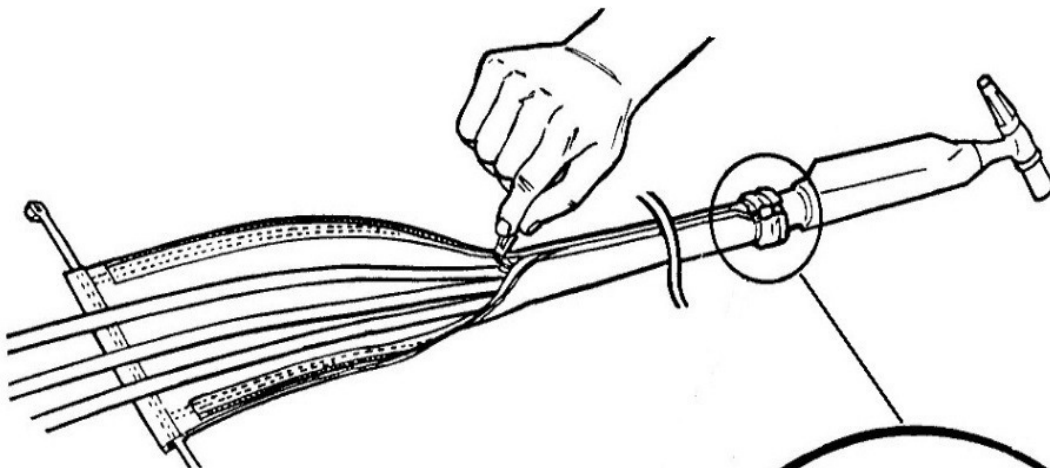

Continue to zip the cover, allowing the cables to lay flat as you zip. Install another cable tie at the machine end of the cover and trim excess. **DO NOT OVER TIGHTEN.**

After installation you may prefer to install an optional cable tie just behind the torch handle. This will smooth any bunching or wrinkles at the torch handle. **DO NOT OVER TIGHTEN** the optional tie.

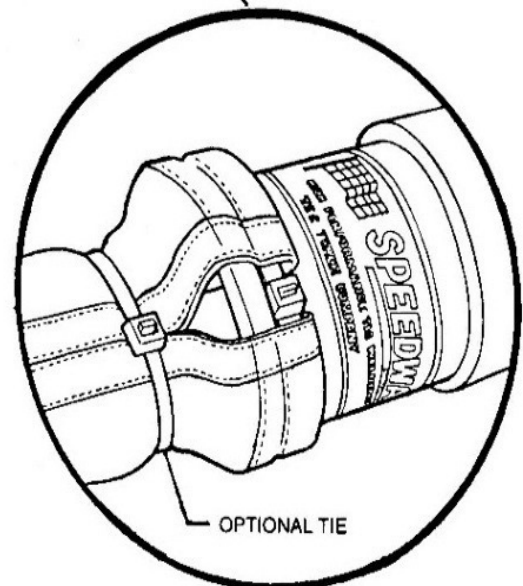

WeldTec®

bullet proof. . .

. . . that's the only way to describe WeldTec's new Overcoat™ leather cable covers.



These unique patented two-piece protective covers are made using a "bullet proof" cowhide leather main cover and a glove soft leather extension cover. They are designed specifically to bundle and protect the expensive hoses and cables used on TIG torches, MIG guns and plasma torches.

The cowhide leather cover will take the abuse of being dragged on the shop floor, over the weld fixture and even over sharp edges on the work piece. It is not affected by sparks, spatter, flames, heat or cold and is closed with a "bullet proof" Velcro® closure that will not arc-out or melt and is double stitched with heat resistant Kevlar® thread for durability.

The 6 foot glove soft leather extension cover is fitted with a non-conductive zipper closure and extends from the cowhide cover up to the TIG torch handle giving the operator a light weight, highly flexible protective cover at the torch end. The softer extension cover resists burns, tears, cuts and does not pickup grinding burrs. The two covers can easily be replaced separately if needed.

These protective covers will pay for themselves many times over in reduced cable/hose replacement costs and reduced down time.

Complete 2 Piece Sets

Part Number	Description	Torch Length
TOC-12	12 ft. Overcoat Leather Cable Cover Set	12.5ft
TOC-24	24 ft. Overcoat Leather Cable Cover Set	25ft



Covers bundles up to 3/4" diameter

Replacement Individual Cover segments

Part Number	Description	Torch Length
TOC-6P	3" Pigskin Leather Zipper Cover 6ft	12.5ft and 25ft
TOC-6CH	4" Cowhide Leather Velcro Cover 6ft	12.5ft
TOC-18CH	4" Cowhide Leather Velcro Cover 18ft	25ft

TOC-12	Overcoat Leather Cable Cover Set 12ft	Each	74.00
TOC-24	Overcoat Leather Cable Cover Set 24ft	Each	148.00
TOC-6P	Replacement 3" Pigskin Leather Zipper Cover - 6ft	Each	33.80
TOC-6CH	Replacement 4" Cowhide Leather Velcro Cover - 6ft	Each	41.00
TOC-18CH	Replacement 4" Cowhide Leather Velcro Cover - 18ft	Each	115.00

ALL PRICES ARE IN POUNDS STERLING (GBP) and EXCLUDE VAT .

CARRIAGE is EXTRA.

TO ORDER:-

Telephone +44 (0)1942 497 387

email: info@weldmarkuk.com

WELDMARK LTD

Hodson Street

WIGAN

Lancashire

WN3 4EN

UNITED KINGDOM